

# \*TB 9-6625-2043-24

DEPARTMENT OF THE ARMY TECHNICAL BULLETIN

## CALIBRATION PROCEDURE FOR RF POWER METER BOONTON ELECTRONICS MODELS 42B, AND 42BD WITH POWER DETECTORS BOONTON ELECTRONICS, MODELS 41-4A, 41-4B AND 41-4E

Headquarters, Department of the Army, Washington, DC

11 January 2008

*Distribution Statement A: Approved for public release; distribution is unlimited.*

### REPORTING OF ERRORS AND RECOMMENDING IMPROVEMENTS

You can improve this manual. If you find any mistakes or if you know of a way to improve these procedures, please let us know. Mail your letter or DA Form 2028 (Recommended Changes to Publications and Blank Forms) directly to: Commander, U.S. Army Aviation and Missile Command, ATTN: AMSAM-MMC-MA-NP, Redstone Arsenal, AL 35898-5000. A reply will be furnished to you. You may also send in your comments electronically to our E-mail address: [2028@redstone.army.mil](mailto:2028@redstone.army.mil) or by fax 256-842-6546/DSN 788-6546. For the World Wide Web use: <https://amcom2028.redstone.army.mil>. Instructions for sending an electronic 2028 can be found at the back of this manual.

SECTION		Paragraph	Page
I.	IDENTIFICATION AND DESCRIPTION		
	Test instrument identification .....	1	2
	Forms, records, and reports.....	2	2
	Calibration description .....	3	2
II.	EQUIPMENT REQUIREMENTS		
	Equipment required .....	4	3
	Accessories required.....	5	4
III.	CALIBRATION PROCESS		
	Preliminary instructions.....	6	4
	Equipment setup .....	7	5
	Calibration factor control.....	8	5
	Electrical meter zero .....	9	6
	Main gain.....	10	6

\*This bulletin supersedes TB 9-6625-2043-35, dated 23 March 2005, including all changes.

	<b>Paragraph</b>	<b>Page</b>
Recorder full scale sensitivity .....	11	8
Meter sensitivity .....	12	9
dBm ranging (model 42BD only).....	13	10
RF calibration accuracy .....	14	10
Chopper frequency .....	15	12
Low voltage power supply.....	16	12
Final procedure .....	17	12

**SECTION I  
IDENTIFICATION AND DESCRIPTION**

**1. Test Instrument Identification.** This bulletin provides instructions for the calibration of RF Power Meter, Boonton Electronics Models 42B, and 42BD with, Power Detectors, Boonton Electronics, Models 41-4A, 41-4B, and 41-4E. The manufacturers' manuals and TM 11-6625-2857-14 were used as the prime data sources in compiling these instructions. The equipment being calibrated will be referred to as the TI (test instrument) throughout this bulletin.

**a. Model Variations.** The calibration procedure was written around the Analog Model 42B. Some control settings are different and not required for the digital models. When different, the adjustments for model 42BD are shown in parenthesis.

**b. Time and Technique.** The time required for this calibration is approximately 4 hours, using the dc and low frequency and microwave techniques.

**2. Forms, Records, and Reports**

**a.** Forms, records, and reports required for calibration personnel at all levels are prescribed by TB 750-25.

**b.** Adjustments to be reported are designated (R) at the end of the sentence in which they appear. When adjustments are in tables, the (R) follows the designated adjustment. Report only those adjustments made and designated with (R).

**3. Calibration Description.** TI parameters and performance specifications which pertain to this calibration are listed in table 1.

Table 1. Calibration Description

Test instrument parameters	Performance specifications
Power requirements	115 V ac $\pm 10\%$ , 50 to 400 Hz, 15 W
Frequency range	200 kHz to 12.4 GHz with 41-4B power detector 200 kHz to 18 GHz with 41-4E power detector 200 kHz to 7 GHz with 41-4A power detector
Power range	1 nW (-60 dBm) to 10 mW (+10 dBm) in 7 decade ranges
Accuracy (model 42B): Six highest ranges (-50 to +10 dBm)	200 kHz to 4 GHz: $\pm(0.5\%$ of FS +0.2 dB) Approximates $\pm 6.27\%$ at 1 mW 4 to 8.2 GHz: $\pm(0.5\%$ of FS +0.05 dB/mW +0.3 dB) Approximates $\pm 8.58\%$ at 1 mW 8.2 to 12.4 GHz: $\pm(0.5\%$ of FS +0.05 dB/mW +0.4 dB) Approximates $\pm 10.9\%$ at 1 mW
Lowest range (-60 to -50 dBm)	200 kHz to 4 GHz: $\pm(1.0\%$ of FS +0.4 dB) Approximates $\pm 10.22\%$ 4 to 8.2 GHz: $\pm(1.0\%$ of FS +0.5 dB) Approximates $\pm 12.54\%$ 8.2 to 12.4 GHz: $\pm(1.0\%$ of FS +0.6 dB) Approximates $\pm 14.86\%$
Accuracy <sup>1</sup> (model 42BD): Six highest ranges (-50 to +10 dBm)	$\pm 0.2$ dB $\pm 1$ digit from 200 kHz to 4 GHz $\pm 0.3$ dB $\pm 1$ digit from 4 to 8.2 GHz $\pm 0.4$ dB $\pm 1$ digit from 8.2 to 12.4 GHz $\pm 0.6$ dB $\pm 1$ digit from 12.4 to 18 GHz
Lowest range (-60 to -50 dBm)	$\pm 0.4$ dB $\pm 1$ digit from 200 kHz to 4 GHz $\pm 0.5$ dB $\pm 1$ digit from 4 to 8.2 GHz $\pm 0.6$ dB $\pm 1$ digit from 8.2 to 12.4 GHz $\pm 0.8$ dB $\pm 1$ digit from 12.4 to 18 GHz

<sup>1</sup>On the 10 mW (+10 dBm) FS range only, add  $\pm 0.5$  dB to the accuracy statement for frequencies above 4 GHz.

## SECTION II EQUIPMENT REQUIREMENTS

**4. Equipment Required.** Table 2 identifies the specific equipment to be used in this calibration procedure. This equipment is issued with Secondary Transfer Calibration Standards Set AN/GSM-287 or AN/GSM-705. Alternate items may be used by the calibrating activity. The items selected must be verified to perform satisfactorily prior to use and must bear evidence of current calibration. The equipment must meet or exceed the minimum use specifications listed in table 2. The accuracies listed in table 2 provide a four-

to-one ratio between the standard and TI. Where the four-to-one ratio cannot be met, the actual accuracy of the equipment selected is shown in parenthesis.

**5. Accessories Required.** The accessories required for this calibration are common usage accessories issued as indicated in paragraph 4 above and are not listed in this calibration procedure.

Table 2. Minimum Specifications of Equipment Required

Common name	Minimum use specifications	Manufacturer and model (part number)
FREQUENCY COUNTER	Range: 10 to 11 ms Accuracy: $\pm 0.1\%$	Fluke, Model PM6681/656 (PM6681/656)
FUNCTION/ARBITRARY GENERATOR	Frequency: 200 kHz Amplitude: 0.1 mV to 1.0 V	Agilent, Model 33250A (33250A)
MULTIMETER	Range: 1 to 16 V dc Accuracy: $\pm 0.1\%$	Fluke, Model 8840A/AF05 (AN/GSM-64D)
POWER METER	Range: -10 to 0 dBm Accuracy: $\pm 5\%$	Agilent, Model E12-432A (MIS-30525) w/thermistor mount, Agilent, Model 478A- H75- (7915907) or 8478B (8478B)
POWER SPLITTER	Range: 1 to 12 GHz	Weinschel, Model 1870A (7916839)
SYNTHESIZED SIGNAL GENERATOR	Range: 1 to 12 GHz Accuracy: $\pm 1\%$ Amplitude: +13 dBm minimum	Anritsu, Model 68369NV (68369NV)
TRUE RMS VOLTMETER	Frequency: 200 kHz Accuracy: $\pm 0.02\%$ ( $\pm 0.5\%$ )	Fluke, Model 8922A/AA (8922A/AA)

### SECTION III CALIBRATION PROCESS

#### 6. Preliminary Instructions

a. The instructions outlined in paragraphs 6 and 7 are preparatory to the calibration process. Personnel should become familiar with the entire bulletin before beginning the calibration.

b. Items of equipment used in this procedure are referenced within the text by common name as listed in table 2.

c. Unless otherwise specified, verify the result of each test and, whenever the test requirement is not met, take corrective action before continuing with the calibration. Adjustments required to calibrate the TI are included in this procedure. Additional maintenance information is contained in the manufacturers' manuals and TM 11-6625-2857-14 for this TI.

d. When indications specified in paragraphs 8 through 14 are not within tolerance, perform the power supply check prior to making adjustments. After adjustments are made,

repeat paragraphs 8 through 14. Do not perform power supply check if all other parameters are within tolerance.

- e. Unless otherwise specified, all controls and control settings refer to the TI.

## 7. Equipment Setup

### WARNING

HIGH VOLTAGE is used or exposed during the performance of this calibration. DEATH ON CONTACT may result if personnel fail to observe safety precautions. REDUCE OUTPUT(S) to minimum after each step within the performance check where applicable.

### NOTE

Calibrate model 42BD with matching serial numbered power detector.

- a. Do not remove protective cover from TI until required for adjustments.
- b. Connect power detector (supplied with TI) to **POWER DETECTOR** terminal and be sure that connectors are tight on TI cable connecting power detectors.
- c. Set 230-115 line voltage selector switch on rear panel to 115 position and verify that line voltage fuse holder is equipped with a 0.2-A (0.1 on some models), 115 V slow blow fuse.
- d. Adjust mechanical zero adjustment screw, located in bezel below meter face, for zero indication (not on all models).
- e. Position controls as listed in (1) through (4) below:
  - (1) Power switch to off (OFF).
  - (2) **FULL SCALE** switch to **+10 dBm**.
  - (3) **CAL FACTOR** control to **0**.
  - (4) **ZERO** control fully ccw.
- f. Connect TI to a 115 V ac source.
- g. Set TI power switch to on (**PWR**) and allow 5 minutes for TI to warm-up and stabilize.
- h. Zero TI by performing (1) through (5) below:
  - (1) Remove RF power from TI power detector. Avoid unnecessary handling of TI power detector to minimize thermal disturbances.
  - (2) Set **FULL SCALE** switch to **-50 dBm**.
  - (3) Adjust **ZERO** control until average indication of TI meter is at downscale zero mark (minus sign flashes on and off).
  - (4) Set **FULL SCALE** switch to appropriate range for power to be measured.
  - (5) Reapply RF power to TI power detector.

## 8. Calibration Factor Control

- a. Performance Check

(1) Set **CAL FACTOR** control against mechanical stop on + (positive) side of **CAL FACTOR** dial. Note position of **CAL FACTOR** control relative to +1 on dial.

(2) Set **CAL FACTOR** control against mechanical stop on - (negative) side of **CAL FACTOR** dial. If position of **CAL FACTOR** control relative to -1 on dial is not equal and opposite of that noted in (1) above, perform **b** (1) below.

(3) Set **CAL FACTOR** control to -1 dBm.

(4) Zero TI meter as described in paragraph **7 h** above.

(5) Set **FULL SCALE** switch to -30 dBm (**OFF-PWR-dBm** to **dBm**).

(6) Connect function/arbitrary generator **Output** to TI power detector and set frequency to 200 kHz and set amplitude to minimum setting. (Frequency setting will be maintained throughout remaining calibration checks.)

(7) Press function/arbitrary generator **Output** key and increase amplitude until TI meter indicates -33 dBm.

(8) Set **CAL FACTOR** control to +1 dBm. If TI does not indicate between -30.9 dBm and -31.1 dBm, perform **b** (2) below.

(9) Press function/arbitrary generator **Output** key again to turn off output.

#### **b. Adjustments**

(1) Adjust position of **CAL FACTOR** knob on shaft so that equal and opposite **CAL FACTOR** indications are obtained when control is set against stops (R).

(2) Adjust R573 (fig. 1 or 2) for a -31.0 dBm indication on TI meter (R).

### **9. Electrical Meter Zero**

#### **a. Performance Check**

(1) Connect **RECORDER** output (rear panel) to input of true rms voltmeter. For model 42BD, connect multimeter to **RECORDER** output (rear panel).

(2) Set **CAL FACTOR** control to 0 dBm. This **CAL FACTOR** control setting will be maintained throughout remaining calibration checks at function/arbitrary generator frequency of 200 kHz.

(3) Set **FULL SCALE** switch to -50 dBm (**OFF-PWR-dBm** switch to **PWR**).

(4) Adjust **ZERO** control to an average zero indication (downscale) on TI meter (minus sign flashes on and off). True rms voltmeter will indicate 100 mV or less.

(5) Set **FULL SCALE** switch to -30 dBm. If TI meter (model 42B) does not indicate zero (downscale), perform **b** below. For model 42BD, if multimeter does not indicate 0.0 V dc, perform **b** below.

**b. Adjustments.** Adjust R233 (fig. 1 or 2) for a zero indication (downscale) on TI meter (R). For model 42BD, adjust R233 (fig. 2) for 0.0 V dc indication on multimeter (R).

### **10. Main Gain**

#### **a. Performance Check**

(1) Zero TI meter as described in paragraph **7 h** above.

(2) Remove top protective cover from TI.

(3) Connect equipment as shown in figure 3.

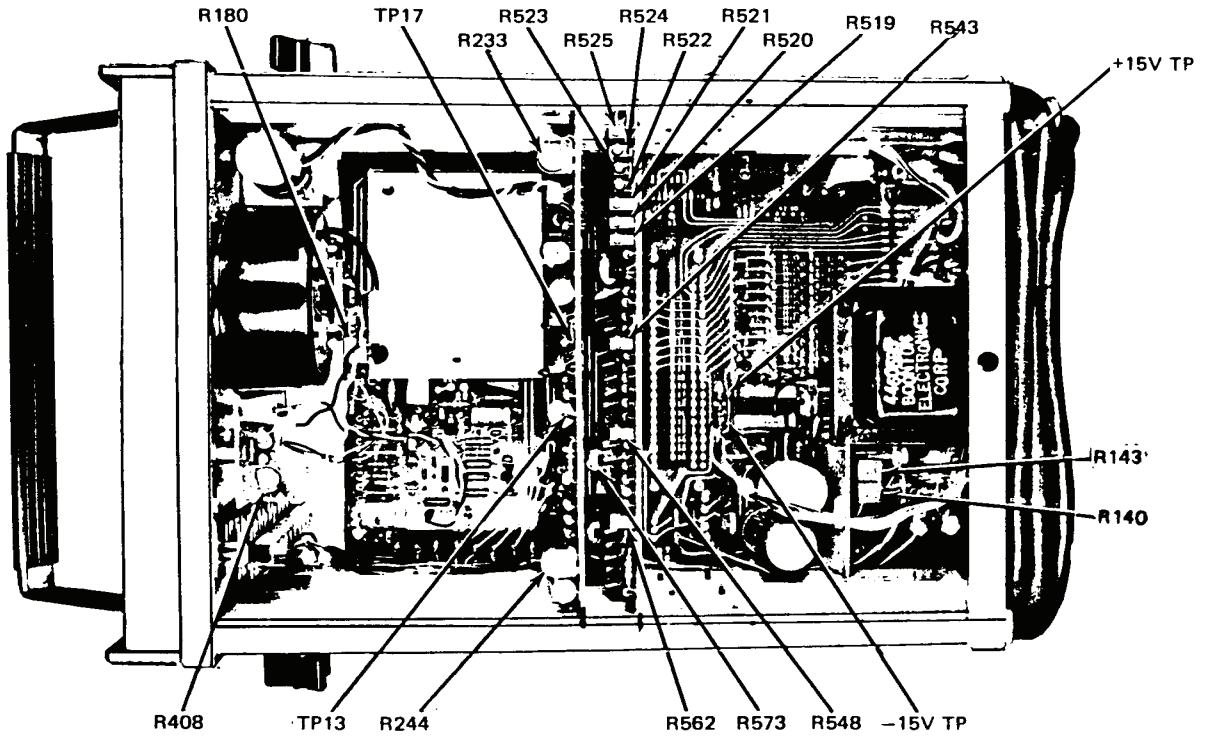

Figure 1. Model 42B - to view.

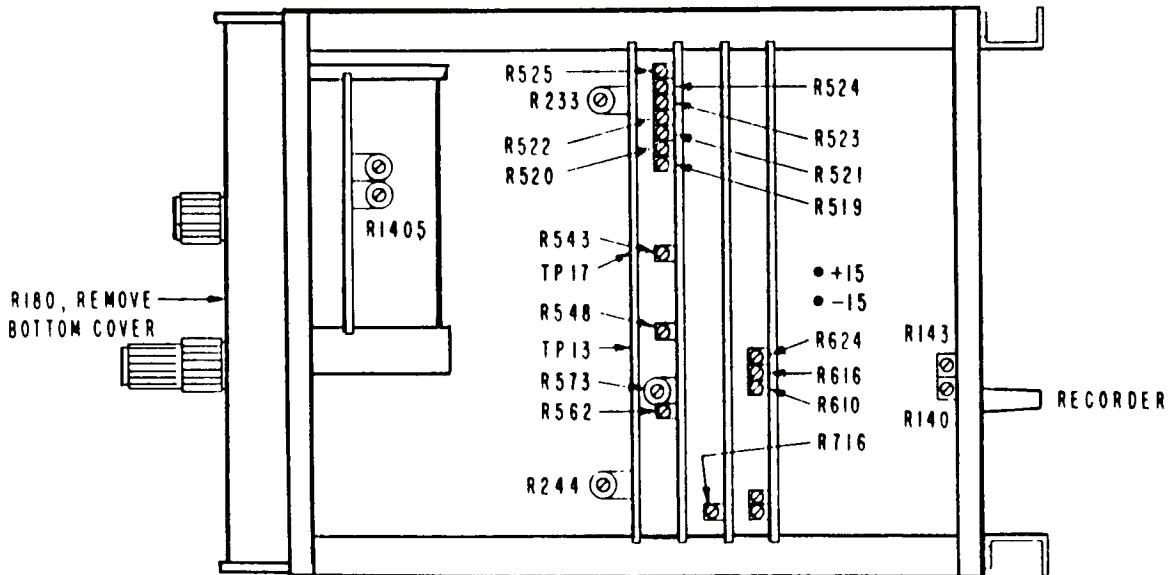

Figure 2. Model 42BD - top view.

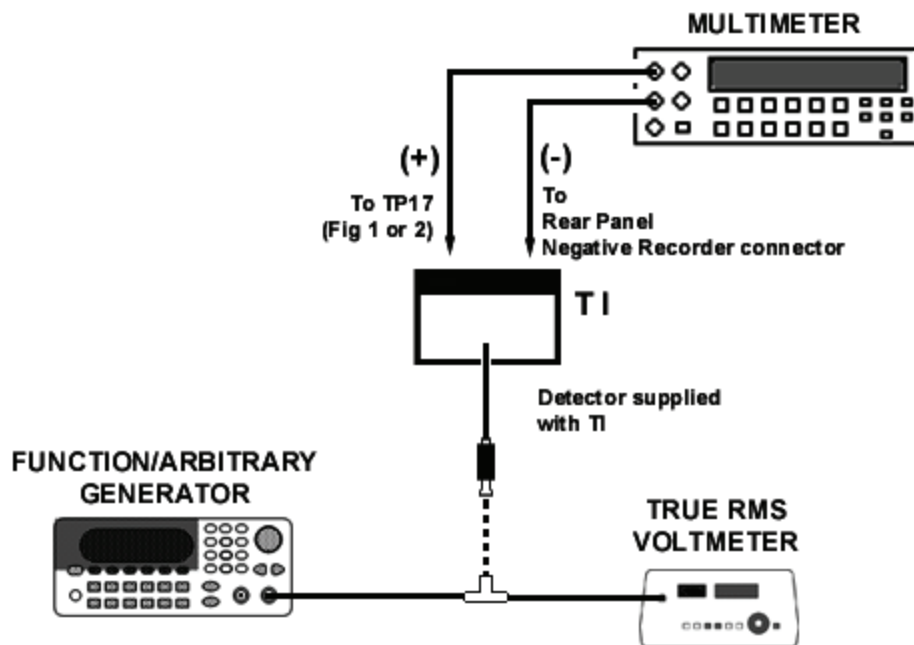

Figure 3. Main gain - equipment setup.

(4) Set **FULL SCALE** switch to -30 dBm.

(5) Adjust function/arbitrary generator rms output for an indication of -3.0 V dc on multimeter. If true rms voltmeter does not indicate between 7.04 and 7.1 mV ac, perform **b** below.

**b. Adjustments**

(1) Adjust function/arbitrary generator output for an indication of 7.07 mV on true rms voltmeter.

(2) Adjust R180 (fig. 1 or 2) for a -3.0 V dc indication on multimeter (R).

**11. Recorder Full Scale Sensitivity**

**a. Performance Check**

(1) Disconnect positive side of multimeter from TP17 and connect to + (positive) **RECORDER** connector on TI rear panel.

(2) Zero TI meter as described in paragraph 7 h above.

(3) Set **FULL SCALE** switch to -30 dBm.

(4) Adjust function/arbitrary generator output for an indication of 10.0 V dc on multimeter. If true rms voltmeter does not indicate between 7.04 and 7.1 mV, perform **b** below.



**b. Adjustments**

(1) Adjust function/arbitrary generator output for an indication of 7.07 mV on true rms voltmeter.

(2) Adjust R523 (fig. 1 or 2) for a 10.0 V dc indication on multimeter (R).

**12. Meter Sensitivity**

**a. Performance Check**

(1) Zero TI meter as described in paragraph 7 h above.

(2) Set **FULL SCALE** switch to -30 dBm.

(3) Adjust function/arbitrary generator output for a TI meter indication of -30 dBm (1.000 μW). If true rms voltmeter does not indicate between -29.65 and -30.35 dBm, perform **b** below.

(4) Repeat technique of (1) through (3) above for values listed in table 3. If true rms voltmeter does not indicate within limits specified, perform corresponding adjustments.

Table 3. Meter Sensitivity

Test instrument		True rms voltmeter indications (dBm)		Adjustments (R)	
FULL SCALE switch positions (dBm)	Meter indications	Min	Max	(figs 1 and 2)	Adjust for indications (dBm)
-50	-50 dBm (10.00 nW)	-49.55	-50.45	R525	-50
-40	-40 dBm (100.0 nW)	-39.6	-40.4	R524	-40
-20	-20 dBm (10.00 μW)	-19.7	-20.3	R522	-20
-10	-10 dBm (100.0 μW)	-9.75	-10.25	R521	-10
-10	-20 dBm (10.0 μW)	-19.75	-20.25	R543	-20
0	0 dBm (1.000 mW)	-0.2	+0.2	R520	0
0	-10 dBm (.100 mW)	-9.8	-10.2	R548	-10
+10	+10 dBm (10.00 mW)	+9.75	+10.25	R519	+10
+10	0 dBm (1.00 mW)	-0.25	+0.25	R562	0

**b. Adjustments**

(1) Adjust function/arbitrary generator output for an indication of -30.00 dBm on true rms voltmeter.

(2) Adjust R408 (fig. 1) or R1405 (fig. 2) for a -30 dBm (1.000 μW) indication on TI meter (R).

### 13. dBm Ranging (Model 42BD Only)

#### a. Performance Check

- (1) Connect TI power detector to function/arbitrary generator **Output**.
- (2) Set **FULL SCALE** range selector switch to 10 mW.
- (3) Adjust function/arbitrary generator frequency control to 200 kHz and adjust output for TI indication of 10 mW.
- (4) Set **OFF-PWR-dBm** switch to **dBm**. If TI does not indicate between +9.8 and +10.2 dBm, perform **b** (1) below.
- (5) Reduce function/arbitrary generator output to minimum.
- (6) Set **FULL SCALE** range selector switch to **100 nW** and **OFF-PWR-dBm** switch to **PWR**.
- (7) Adjust function/arbitrary generator output for TI indication of 100 nW.
- (8) Set **OFF-PWR-dBm** switch to **dBm**. If TI does not indicate between -39.7 and -40.3 dBm, perform **b** (2) below.
- (9) Set **FULL SCALE** range selector switch to 1 mW and **OFF-PWR-dBm** switch to **PWR**.
- (10) Adjust function/arbitrary generator output for a TI indication of 1.0 mW.
- (11) Set **OFF-PWR-dBm** switch to **dBm**. If TI does not indicate between -0.2 and +0.2 dBm, perform **b** (3) below. Record TI indication.
- (12) Reduce function/arbitrary generator output by 10 dB. If TI does not indicate 10  $\pm$ 0.2 dB difference from value recorded in (11) above, perform **b** (4) below.

#### b. Adjustments

- (1) Adjust R610 (fig. 2) for a +10 dBm indication on TI meter (R).
- (2) Adjust R624 (fig. 2) for a -40 dBm indication on TI meter (R).
- (3) Adjust R610 (fig. 2) for a 0 dBm indication on TI meter (R).
- (4) Adjust R616 (fig. 2) until TI indicates a 10 dB difference from value recorded in **a** (11) above (R).

### 14. RF Calibration Accuracy

#### a. Performance Check

- (1) Connect equipment as shown in figure 4.

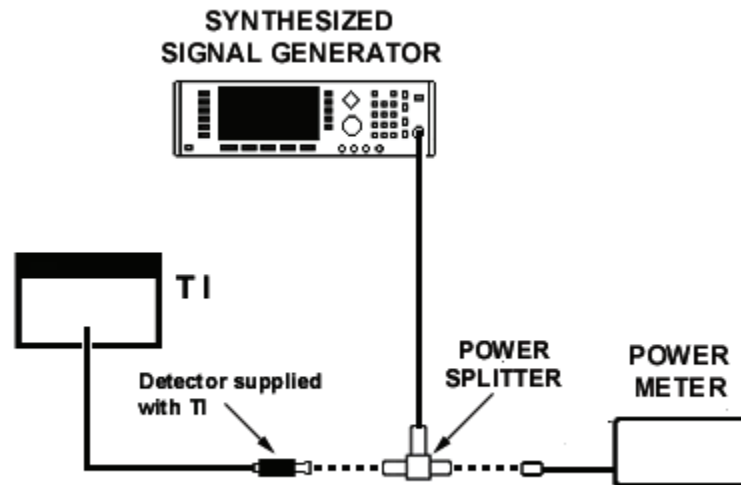

Figure 4. RF calibration - equipment setup.

(2) Set synthesized signal generator for CW operation at a frequency of 10 GHz (7 GHz for model 41-4A).

(3) Determine calibration factor of thermistor mount (p/o power meter) at 10 GHz (7 GHz for model 41-4A) from calibration data label.

(4) Set **CALIB FACTOR** control of power meter to appropriate value.

(5) Determine calibration factor of TI power detector from calibration chart attached to detector. Set **CAL FACTOR** control to this value

(6) Zero TI meter as described in paragraph 7 h above.

(7) Set **FULL SCALE** switch to 0 dBm and **OFF-PWR-dBm** switch to **dBm**.

(8) Set synthesized signal generator output **ON** and adjust level control for a -1 dBm indication on power meter. TI meter will indicate between -1.41 and -0.59 dBm. Record TI indication.

(9) Reverse connection of power meter thermistor mount and TI power detectors at power splitter and repeat (3) through (8) above. Average of two values will be within limits specified.

(10) Repeat (2) through (9) above at 5 and 1 GHz. TI meter will indicate between -1.31 and -0.69 (-1.21 and -0.79 dBm), respectively.

**b. Adjustments.** No adjustments can be made.

## 15. Chopper Frequency

### a. Performance Check

#### NOTE

Do not perform chopper frequency checks if all other parameters are within tolerance.

- (1) Connect negative edge of frequency counter to **RECORDER** connector on rear panel and positive side of frequency counter to TP13 (fig. 2).
- (2) Connect TI power detector to function/arbitrary generator **Output**.
- (3) Zero TI meter as described in paragraph **7 h** above.
- (4) Set **FULL SCALE** switch to **-30 dBm**.
- (5) Adjust function/arbitrary generator output for a -30 dBm indication on TI meter.
- (6) Set frequency counter to measure period. If frequency counter does not indicate between 10.50 and 10.80 ms, perform **b** below.

**b. Adjustments.** Adjust R244 (fig. 1 or 2) for a 10.65 ms indication on frequency counter (R).

## 16. Low Voltage Power Supply

#### NOTE

Do not perform power supply check if all other parameters are within tolerance.

### a. Performance Check

- (1) Connect negative side of multimeter to - (negative) **RECORDER** connector on rear panel, and positive side of multimeter to -15 V TP (fig. 1 or 2). If multimeter does not indicate between -14.9 and - 15.1 V dc, perform **b** (1) below.
- (2) Connect positive test lead to +15 V TP (fig. 1 or 2). If multimeter does not indicate between +14.9 and +15.1 V dc, perform **b** (2) below.

### b. Adjustments

- (1) Adjust R143 (fig. 1 or 2) for a -15.0 V dc indication on multimeter (R).
- (2) Adjust R140 (fig. 1 or 2) for a +15.0 V dc indication on multimeter (R).

## 17. Final Procedure

- a. Deenergize and disconnect all equipment.
- b. Annotate and affix DA label/form in accordance with TB 750-25.

By Order of the Secretary of the Army:

Official:

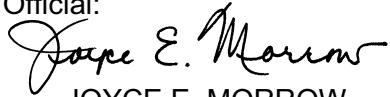

JOYCE E. MORROW  
*Administrative Assistant to the  
Secretary of the Army*

0732306

GEORGE W. CASEY, JR.  
*General, United States Army  
Chief of Staff*

Distribution:

To be distributed in accordance with the initial distribution number (IDN) 342197, requirements for calibration procedure TB 9-6625-2043-24.



### Instructions for Submitting an Electronic 2028

The following format must be used if submitting an electronic 2028. The subject line must be exactly the same and all fields must be included; however, only the following fields are mandatory: 1, 3, 4, 5, 6, 7, 8, 9, 10, 13, 15, 16, 17, and 27.

From: "Whomever" [whomever@redstone.army.mil](mailto:whomever@redstone.army.mil)  
To: <2028@redstone.army.mil

Subject: DA Form 2028

1. **From:** Joe Smith
2. **Unit:** home
3. **Address:** 4300 Park
4. **City:** Hometown
5. **St:** MO
6. **Zip:** 77777
7. **Date Sent:** 19-OCT-93
8. **Pub no:** 55-2840-229-23
9. **Pub Title:** TM
10. **Publication Date:** 04-JUL-85
11. **Change Number:** 7
12. **Submitter Rank:** MSG
13. **Submitter FName:** Joe
14. **Submitter MName:** T
15. **Submitter LName:** Smith
16. **Submitter Phone:** 123-123-1234
17. **Problem:** 1
18. **Page:** 2
19. **Paragraph:** 3
20. **Line:** 4
21. **NSN:** 5
22. **Reference:** 6
23. **Figure:** 7
24. **Table:** 8
25. **Item:** 9
26. **Total:** 123
27. **Text**

This is the text for the problem below line 27.







